

Maintenance & Cleaning Instructions

S'Match-It Wood

15 02 2012



NOTA BENE

As a natural and living material, wood is moving due to relative humidity (RH). The wood shrinks in dry conditions and it expands in high relative humidity. In areas where the wood has been influenced by high or low RH for a longer period, damage in the wood may arise. Therefore it is important to keep the RH in the hall between 40-60%.

The application of excessive amount of water on timber flooring (repeated washing with an automatic machine or a mop, leakage from the roof, etc.) will cause serious damage.

An important accidental variation of atmospheric conditions (temperature & air moisture content) could cause serious irreversible deterioration on the timber floor.

Compliance with our routine maintenance instructions will ensure that levels of sports performance, cleanliness and hygiene are maintained. In case of none compliance with these prescriptions, Tarkett Sports get out of responsibility of any timber floor damages.

If you need any further information, please contact your dealer who will provide you with the appropriate advice.

The objective of the routine maintenance of timber flooring should be:

- To maintain its sports characteristics, like gloss and friction *.
- To maintain conditions of hygiene, despite the intensive use of the facility.
- To keep the flooring clean and to maintain its appearance.

* It's required to note that friction on the floor is extremely sensible to cleaning and quantity of dust on the sports timber floor. It's recommended to do a regular cleaning to keep sports performances.

CLEANING ADVICE

The introduction of foreign elements, such as dust or gravel (creating mechanical abrasion) will cause damage to the flooring. We recommend the installation of antistatic door mats in the entrances of the sports hall and use of specific shoes in order to reduce this phenomenon.

- Dust should be removed from the flooring by using a mop (dry) or a vacuum cleaner. Frequency: daily.
- Wet cleaning can be carried out using a slightly damp gauze cloth ("bride's veil" type). Frequency: every 2 to 3 days.

Maintenance & Cleaning Instructions

S'Match-It Wood

15 02 2012

- Excessive amounts of water to the flooring can cause serious damage. Thus, washing with a wet mop or a traditional motorised machine is proscribed. Take care also, to protect the floors of squash courts when washing the walls.
- For mechanical cleaning, Tarkett Sports recommends using the appropriate ROTOWASH machine (B60) or equivalent. Rotowash will send staff to give you a demonstration on site at your request (contact details at the end of the document). Cleaning with a Rotowash can be carried out by using water with or without detergent (any detergent used shall be pH neutral, used in the proportions recommended by the manufacturer).
- Remove traces of tar or rubber by using a rag soaked in acetone or trichloroethylene.
- Remove traces of the resin, used by handball players, by using Dynatech Trophy detergent (contact details at the end of the document). We recommend not allowing the resin to "age" on the court and removing it as soon as possible. A rag soaked in DYNATECH Trophy * should be used, or an attempt can be made, to remove the resin using a Rotowash machine and the DYNATECH Trophy* product (allow the product to act and then brush off).

* Respect conditions of use from producer's company. A non respect should cause serious damage.

Atmospheric conditions of use

- Air moisture content required.

These requirements are established between temperatures from 15 to 20 °C.

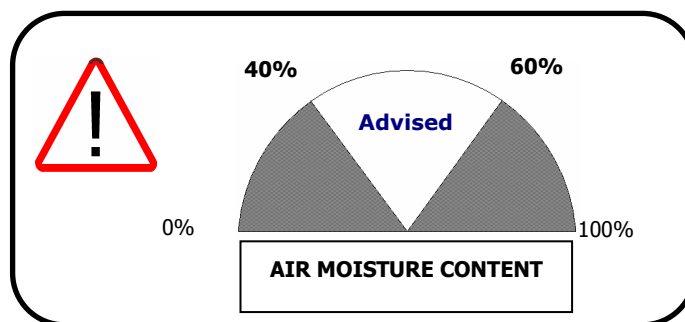

- A temperature between 15 to 20 °C is recommended in the sports hall where the timber sports floor is installed. Important, Accidental, and none natural temperature variations could cause physical damage. The regularly-maintained temperature must be sufficient to prevent condensation that would cause damage to the flooring (keep it above the dew point).

Loading capacity

Types of loads

Each timber floor has its own loading capacity. This loading capacity will depend on intrinsic (construction of the flooring, type of board, timber specie) and extrinsic factors (point loads or distributed loads).

- **A point load** is one that is applied to a small area of contact. This is typically the leg of an item of gymnastics equipment, the wheels of a mobile basket ball basket, or of a stand, etc. Generally, pressures are relatively high, and it is this type of loading that is particularly damaging for timber flooring. If the point load exceeds the permissible value given below, a spreader should be used to spread the load. It will, then, become a distributed load.
- **A distributed load** is applied through a spreader which spreads out the load. The load is generally applied over several of the battens supporting the floor. The pressure levels are thus lower and the load does not therefore cause damage.

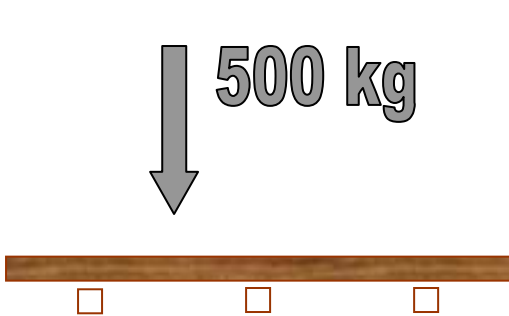
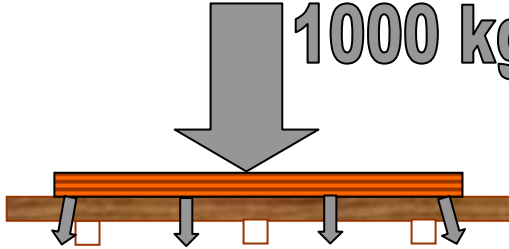
| | |
|--|--|
|  |  |
| <p><i>Fig. 1: Point load of 500 kg. The pressure is high, as the area in contact with the flooring is low. This configuration is potentially damaging.</i></p> | <p><i>Fig. 2: Distributed load of 1 tonne. Although the load is a point load, the inserted spreader spreads the load over the flooring. The pressure remains low and this configuration is not potentially damaging.</i></p> |

Permissible loads: recommendations

- Point loads – Recommendations

| Type of flooring | Point load | Minimum spacing between loads |
|----------------------------|------------|-------------------------------|
| Reflex M Evolution* | 250 kg | 500 mm |
| Proflex M * | 250 kg | 500 mm |
| Sportable * | 250 kg | 600 mm |
| Multiflex M | 350 kg | 300 mm |

Table 1: Permissible point loads for the various systems.

* For the Reflex M Evolution, Proflex and Sportable systems, strengthening can be provided to take loads in excess of the set limit. Please consult us.

Caution: Compliance with the point loads given in table 1 does not mean that the timber will not be left with a permanent indentation. We recommend the use of contact elements that do not make an indentation (polyurethane wheels for example), or of a timber spreader in the event of doubt.

In the case of heavy items of apparatus on wheels, their track can be protected as shown in figure 3.

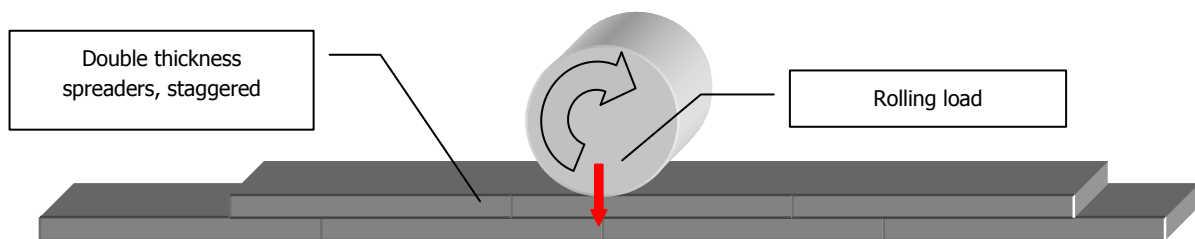

Figure 3: The wheel track can be protected with a double thickness timber spreader. The layers of these spreaders should be staggered to prevent forces created by the ends.

- **Distributed loads – Recommendations**

| Type of flooring | Distributed load * |
|---------------------------|--------------------|
| Reflex M Evolution | 1,000 kg |
| Proflex M | 1,000 kg |
| Sportable | 1,000 kg |
| Multiflex M | 1,200 kg |

Table 2: Permissible distributed loads for the various systems.

* The load shall be distributed by plywood spreaders minimum 600 x 600 mm and 25 mm thick.

Caution: For Sportable, always protect panels' junctions with spreaders when rolling loads are used.

Protection of the flooring during non-sports events

In order to protect the flooring during non-sports events, we recommend the use of Tarkett Sports' "Protectiles". These are compact textile floor covering in needle-punch tiles. Size: 2 x 1 m. Further information is available from Tarkett Sports.

Flexible PVC finishes, such as Touchdown, can also be obtained from Tarkett Sports.

NB : The information given in this data sheet is provided for indicative purposes only. It is the result of our knowledge and our experience. It shall be taken as general maintenance instructions and cannot, by definition, incorporate the actual data for each installation. We therefore reserve the right to modify it at any time.

Contact details for the equipment and products recommended :

Rotowash UK +44 (0) 20 88 47 45 45 www.rotowash.com

Rotowash France +33 (0)2 47 41 55 66 www.rotowash.fr

Dynatech Trophy Tél. : + 33 1 41 91 73 96 www.tanaprofessional.fr