

Installation Instruction

Transport & storage	1
Handling	2
Subfloor control	3
Installation	4
Reminder	5

Exclusive 260
Honeycomb Tile Blue

1. TRANSPORT & STORAGE

In general the rolls must be stored in a sheltered clean and dry indoor place and free from any pollution. Before installation, the rolls with 2m width should be stored upright and safely secured; other dimension above 2m should be stored horizontally.

They should also be protected from extreme temperature (heat and cold), moist, rust, rot, free from any contamination and not piled-up nor crushed under heavy weight. State of the art handling must be respected.

Rolls must be stored during 48 hours before starting the operation.

For installation, room temperature should always be above 15°C.

Check the rules in your country; those temperatures could be different.

Before installation, sheets and tiles should relax minimum 24h, out of packaging.

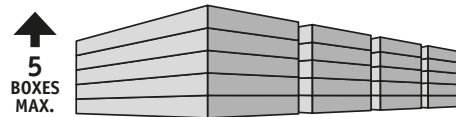

► Products

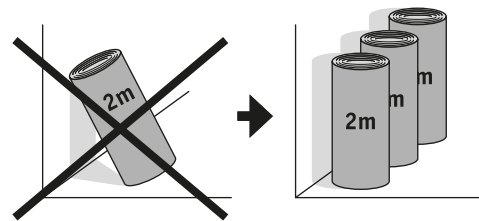

► For 2m rolls: upright storage

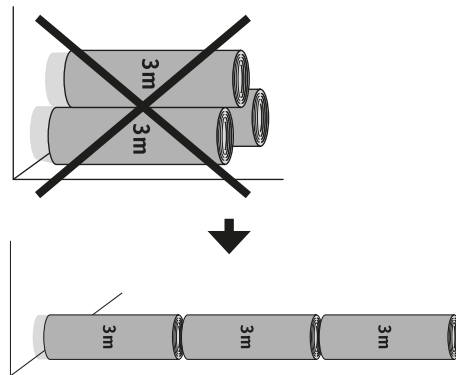

► For $\geq 2m$ rolls: horizontal storage

2. HANDLING



For the best results, follow the installation instructions below, and use the tools and the accessories recommended by the manufacturer.

Care should be taken when handling all types of floorcoverings to ensure that safety procedures are followed and damage does not occur to the material or people.

Check the material for visible defects and/or damage before and during installation and report to Tarkett representative.

For each continuous surface use the same batch number and install rolls/boxes in sequential order

► Trolley

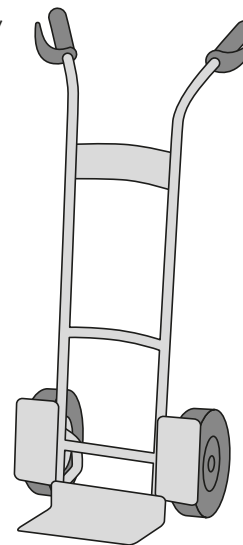

Wrong transport, storage and/or handling could damage the flooring, causing aesthetical or technical issues. Tarkett does not warrant or guarantee flooring problems caused by inappropriate storage or handling.

3. SUBFLOOR CONTROL



The subfloor quality is the 1st condition for a successful installation, so make sure it is in good condition to do a flooring installation.

The subfloor must be flat, clean, free from all debris & residues, without any marks (no felt pen, marker of any type, ballpoint pens, paint, etc. that could cause discolouration due to migration) sound, dry, solid, hard, smooth.

The absorbency must be checked and subfloor should not be exposed to humidity. The preparation/dryness of the subfloor and installation procedures should all be as per the current relevant Standard within the country of use.

The dryness of a solid subfloor should be below the maximum moisture level permitted when tested in accordance with the said Standard. *Check the rules in your country to define the appropriate method and values.*

For marking, only use a non-oily graphite pencil.

3.1 SUBFLOOR CHARACTERISTICS

■ Humidity rate

Always refer to each country regulations. For info, the drying time of a concrete floor is approx 2 weeks per cm. For testing, refer to the regulations valid in your country (Relative Humidity test, Calcium carbide system...).

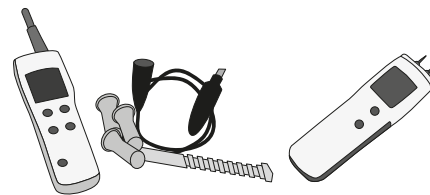

▶ Concrete Moisture Meter

Tip: humidity – plastic sheet

Use a piece of plastic foil (50cmx50cm minimum) that will be placed over the subfloor to control. Fix it with adhesive tape on all the ages to make it hermetic. Wait 24h and check if there is condensation under the foil

- Excessive humidity rate can cause disbonding, bubbles, colour migration that Tarkett does not warrant or guarantee.

■ Absorbency – Porosity

Check local regulations, but in general a subfloor is said too absorbent when the absorbency time of a drop of water on concrete is less than one minute. In this case, a primer must be used before leveling compound, with a 1/1 dilution.

A subfloor is said non-absorbent when the absorbency time of a drop of water on concrete is more than 10/ 15 minutes. In this case, the primer should be used non-diluted.

Prior to the use of a primer, always follow manufacturer's instructions.

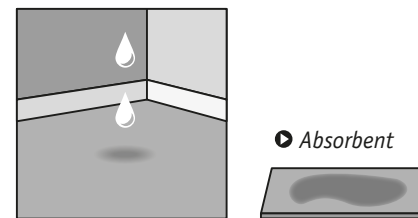

▶ Non-Absorbent

- Non-absorbent subfloor could lead to a longer waiting time of the adhesive generating trouble in the bond plane. Too absorbent subfloor could lead to a shorter waiting time of the adhesive that could cause disbonding issue.

■ Planarity / Flatness

Different ways for measuring acc. countries. France: tolerance must be less than 7mm over 2m for concrete subfloor and 5 mm for wood subfloor.

- UK/Nordic: 3mm over 2m (& depending on localities, SR1 or 2...).
- Germany: 4mm over 2m (Din 18202).
- NL/Australia: 2mm over 2m.

Tolerance must be less than 2mm over 20 cm of concrete/wood subfloor.

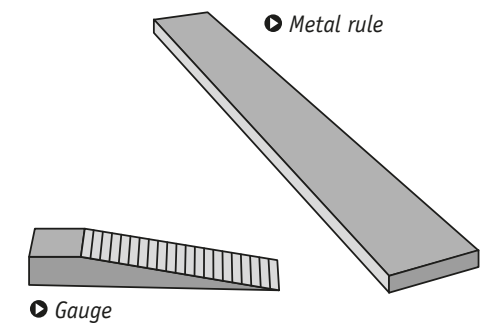

▶ Gauge

- Non-flat surface could lead to visual issues or generate additional cost for the installer when using more levelling compound to recover the surface flatness.

3. SUBFLOOR CONTROL



■ Cracks & joints

First step will be to identify the type of crack or joint that will be discovered on the building site to adapt the treatment.

Cracks

Cracks (0.3 to 1mm large) can appear during the drying of the concrete by contraction.

Micro-cracks

Cracks almost not visible ($\leq 0,3$ mm large).

Expansion joints

Expansion joints are used to compensate dimensional variations and building movements.

Isolating joints

Isolating joints separate the screed from other independent building constructions (walls, pillar).

Contraction (dividing) joints

Contraction joints allow free contraction of concrete and avoid cracks during drying.

Construction joints

Construction joints are used to stop daily pouring of concrete slab.



Mirco-cracks should be treated with a primer.

Cracks and construction joints should be sawed, cleaned and full filled with an epoxy resin on which sand will be spread.

Contraction joints should be full filled with an epoxy resin on which sand will be spread.

Expansion joint will be treated with a profile inserted or overlapped. Levelling compound and floorcovering will be stopped on both sides.

Isolating joints will be filled with soft material (e.g. polystyrene).

■ Hardness

The subfloor has to be resistant enough to compression and indentation. To measure the hardness of the concrete, installer can use a sclerometer.

Tip: hardness – metal key

Use your personal key (metal) to scratch the surface of the subfloor. If the key penetrate the material and if gravels are extracted from the screed, the subfloor could be considered as not hard enough. You could have to use primer and/or levelling compound prior to vinyl installation.

Isolating joints separate the screed from other independent building constructions (walls, pillar).

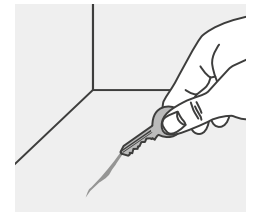

! *When the subfloor is not hard enough, significant traffic or heavy load could damage screed/levelling compound and could cause visual/technical defects.*

■ Sound

The subfloor has to be free from contaminants such as hydrocarbon stains, paints, chemical residues or laitance on the surface.

! *Any contaminant left on the subfloor could cause colour migration and product damage.*

■ Clean

The subfloor has to be free from any particles, dust, traces of felt pen or marker.

! *Particles, scratches and residues could cause visual defect (telegraphing effect).*

3. SUBFLOOR CONTROL



3.3 MATERIALS FOR INSTALLATION

■ Primer

Different types:

solvent/water based, PU, Epoxy.

Main actions:

- grade the site & the over-absorbent and/or different subfloor surfaces.
- grade the permeability of subfloor where drying time could be too quick
- improve the bonding performance of the leveling compound on non-porous subfloor.

Application:

in general, the primer is applied with a brush/roller. Consumption depends on the planarity of the subfloor: 80 - 120 g/m².

Strictly follow manufacturer's instruction.

Applying a leveling compound without using first a primer could cause delamination or cracks of the levelling compound.

■ Self-levelling compound

Definition:

Is a smoothing cement based compound finish for indoor use that will be covered by a floorcovering.

Main actions:

- rectify the subfloor porosity = possibility to glue without any particular preparation
- self levelling action resulting in homogeneous & smooth surface

- allow regularity of glue layer and drying time on the whole surface.

Consumption (average):

1.5 Kg / 1 mm / m²

Heavy duty = 2-3 mm thickness (acc. country).

Strictly follow manufacturer's instructions.

■ Adhesive

Although Tarkett may recommend a selection of manufacturer adhesive, we do not however guarantee the products listed. The list of products and manufacturers are not guaranteed complete or current.

Tarkett would not accept any liability for any of these products failing to perform in conjunction with any of their products.

It is the responsibility of the adhesive manufacturer and flooring contractor to ensure the products being used are appropriate for use and applied in accordance with the manufacturer recommendations.

For best selection, always check:

- Compatibility with the flooring product backing (PVC, PU, jute...)
- Aspect of the backing: rough, smooth, fibers, grid...
- Flooring porosity (textile, jute....)
- Subfloor porosity (absorbent or not)
- Quality/Performance (polyvalence, consumption...).

Consider flooring nature, subfloor type and conditions of use to determine the adhesive type and the spatula. According manufacturer's instructions and building site conditions, determine the drying and working time.

In general:

Moderately absorbent subfloor: use finely notched trowel (approx. 250g/m² to 300g/m²).

- ▶ For compact products (smooth backink): use **A1 spatula** (TKB model).



- ▶ For acoustic products (honey comb foam): use **A2 spatula** (TKB model).



Non absorbent subfloor: use very finely notched trowel (approx. 150g/m² to 200g/m²).

- ▶ May be the case for wall, Tarkolay, etc: use **A4 spatula** (TKB model).

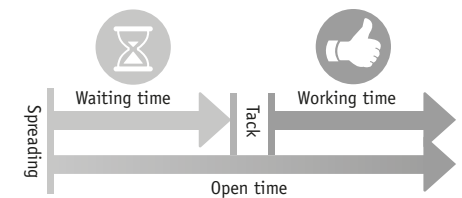

Waiting time = time needed till you are able to lay the floorcovering in the glue with correct bonding.

Working time = time for laying, heavy rolling and trimming of the floorcovering.

In general, the application of glue is made with a serrated spatula (TKB ref.: A1 for compact, A2 for acoustic, B1 for Linoleum...) or a roller (for special glue).

Before laying down the floorcovering, in case application require a drying time of the adhesive, always check that water or solvents are evaporated (finger test - no transfer). Other application may require wet bonding (see Manufacturer instruction) like for linoleum or LVT.

Heavy roller must be used to ensure bonding.

For more details on adhesives, please refer to the specific Tarkett Adhesive recommendation list.
http://professionals.tarkett.com/sites/tarkettb2b_int/files/pdf/tarkett-floor-adhesive_recommendations.pdf

4. INSTALLATION

Please refer to each individual installation notice per product range, adhesive chart with Tarkett selection as guide line.



4.1 GENERAL RULES

■ Laying - Sheets

1 ► Room dimensions

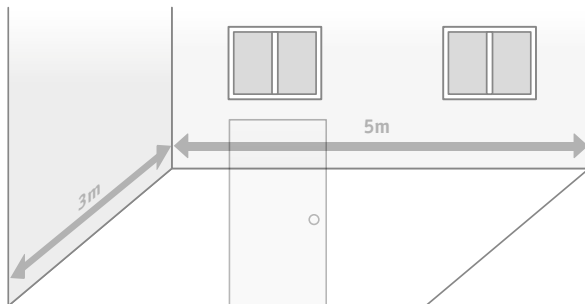

 If the room is reasonably square, the sheets should run parallel to the incoming light. In long, narrow rooms it is best to install the sheets along the length of the room.

2 ► Layout nok

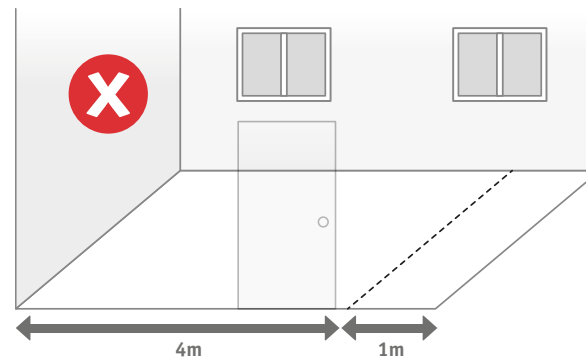

 Joint placed at a door step.

3 ► Layout nok

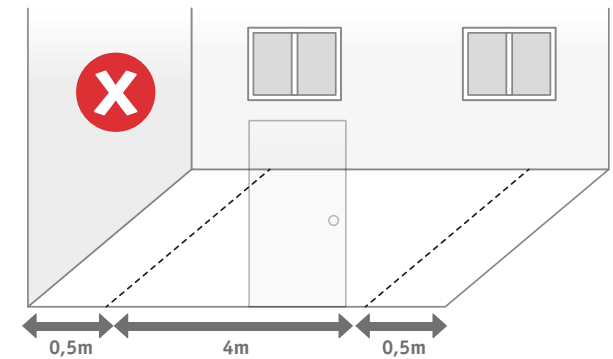

 Loosing material.

4 ► Layout ok

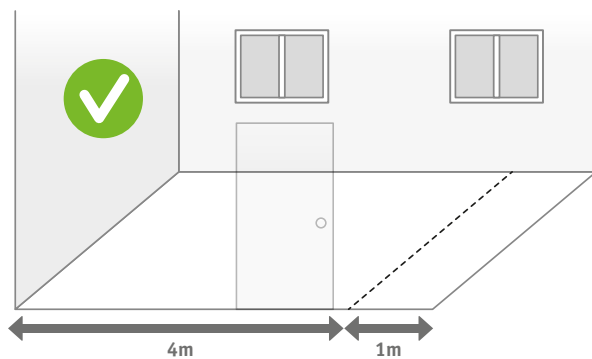

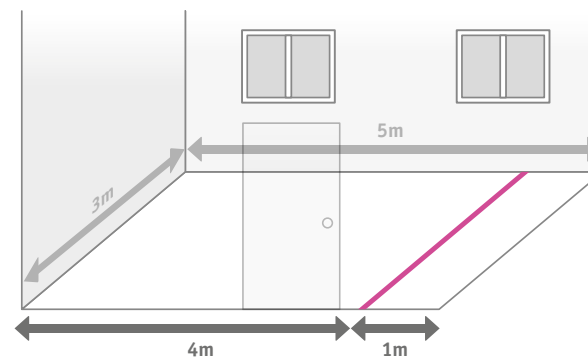

5 ► Reference line

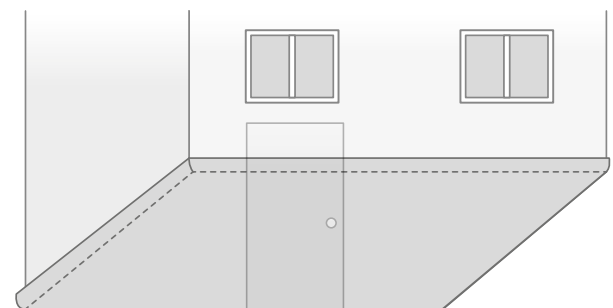

6 ► Sheets preparation (cutting and relaxation)



 Align the sheet edge to the reference line.

 Sections of flooring must be cut to the required lengths, plus an allowance of a few centimeters.

4. INSTALLATION

Please refer to each individual installation notice per product range, adhesive chart with Tarkett selection as guide line.



■ Laying - Sheets

7 ◉ Half folding or rolling

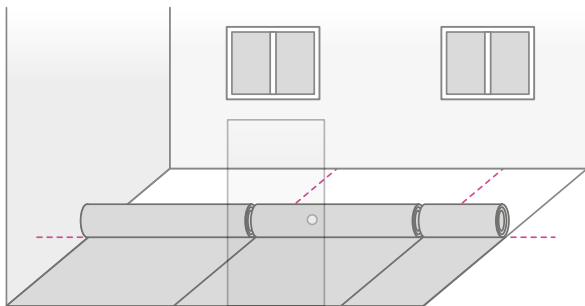

Can be rolled or fold.

8 ◉ Gluing

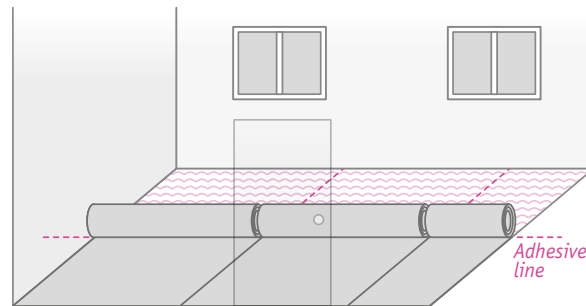

Here, please use Tarkospray.

References:

GB/FR/DE/NL/PL: 1460 003

GB/SW/SPA/IT/PT: 1460 008

7 ◉ First sheet folding back into the adhesive and pressing

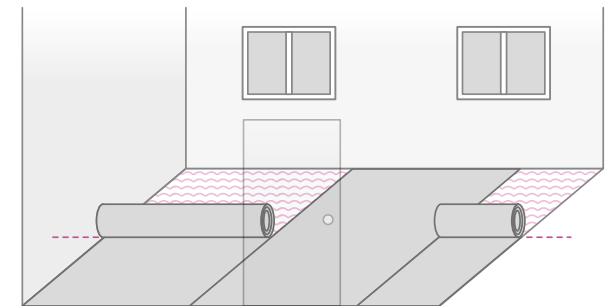

It's important to use the cork press when you gradually roll out the sheets onto the adhesive. In this way, you will avoid catching air under the sheets that may cause blisters later on.

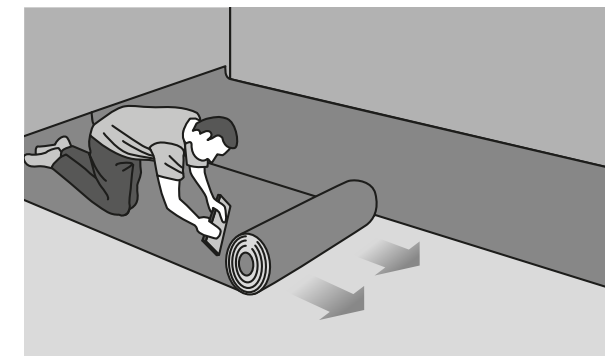

4. INSTALLATION

Please refer to each individual installation notice per product range, adhesive chart with Tarkett selection as guide line.



■ Laying - Sheets

10 ● Next sheets folding back and pressing

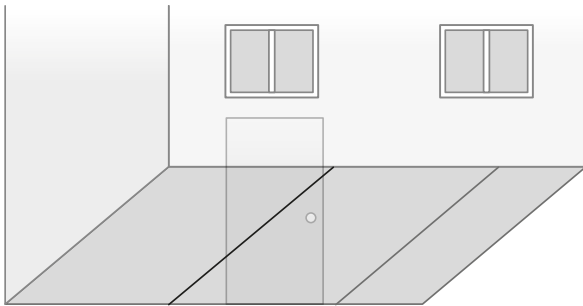

11 ● Repeat for the second half

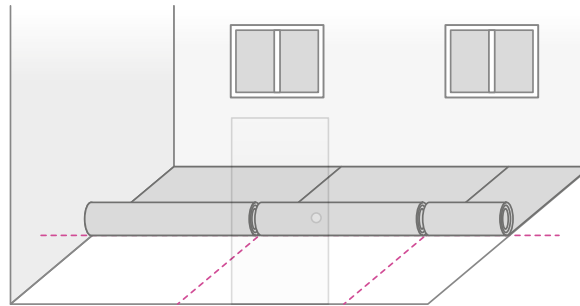

12 ● Gluing

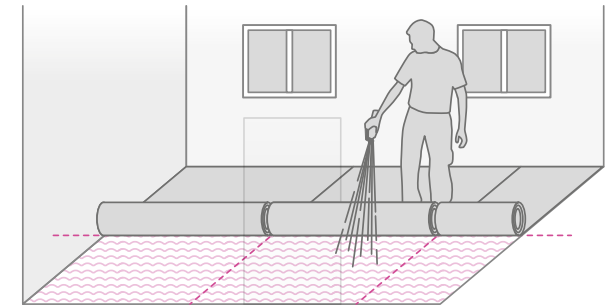

Here, use Tarkospray.

13 ● First sheet folding back into the adhesive and pressing

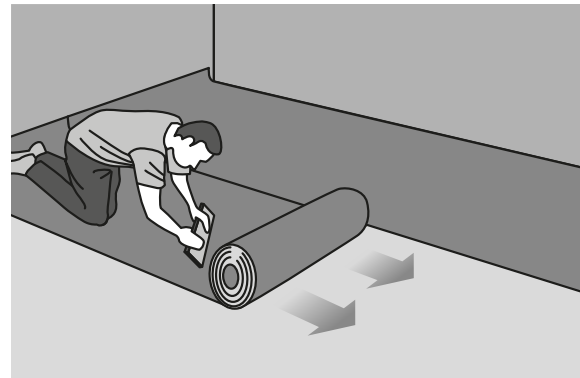
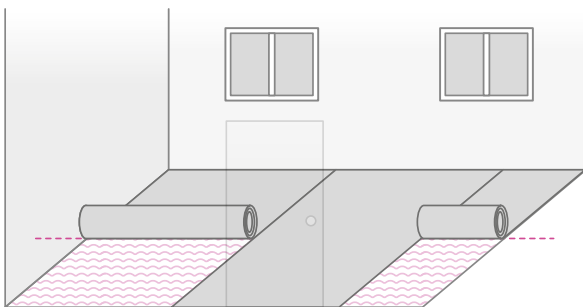

It's important to use the cork press when you gradually roll out the sheets onto the adhesive. In this way, you will avoid catching air under the sheets that may cause blisters later on.

4. INSTALLATION

Please refer to each individual installation notice per product range, adhesive chart with Tarkett selection as guide line.



■ Laying - Sheets

14 ► Next sheets folding back

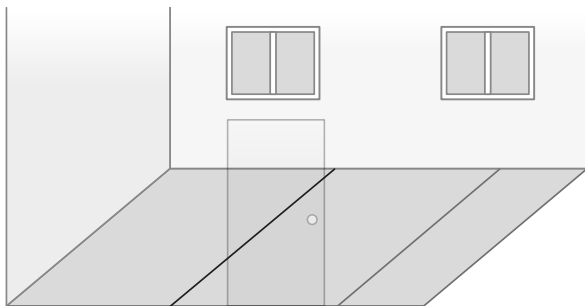

Repeat the same operation with the second half of sheets.

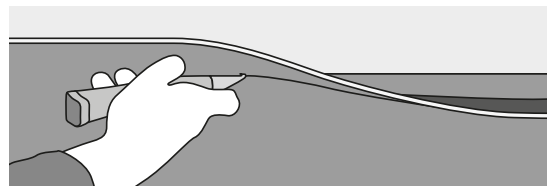

When gluing and pressing is done, excess of material close to walls and obstacles can be trimmed/flushed (freehand cut).

Tools for freehand trimming:

► Knife:



► Hook and concave blades:



► Araseur

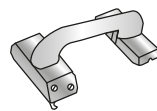

15 ► Final pressing

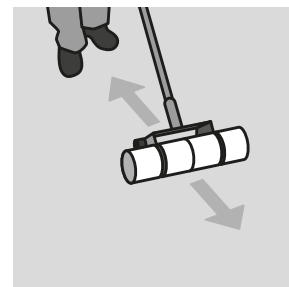
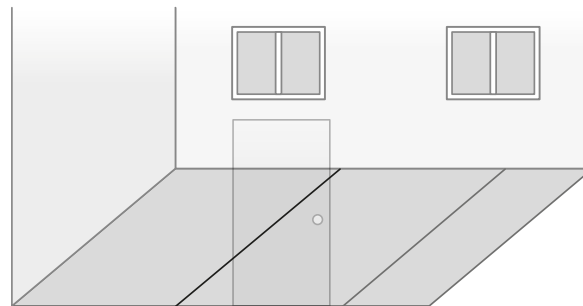

And then, use the heavy roller (mini 50kg) to ensure the final bonding.

Smooth out any and all extra air from the center to the edges with the pressing tool. Do it in the same way for the second half. Cut off (trim) extra material along the walls with cutter or debeader.

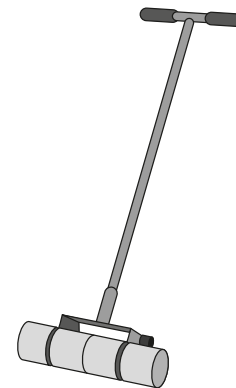

16 ► Hot or cold welding

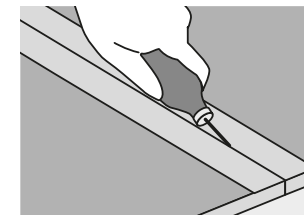
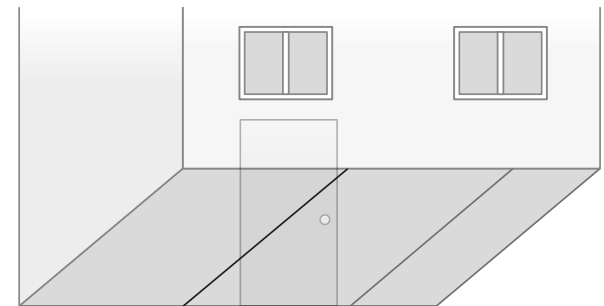

More detail page 11 & 12

4. INSTALLATION

Please refer to each individual installation notice per product range, adhesive chart with Tarkett selection as guide line.



Cold welding (min. 24h after installation):

► Overlap flooring and cut both layers

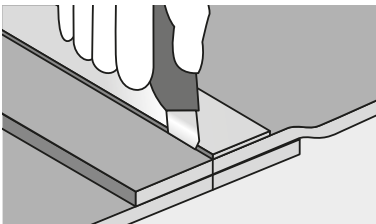

- Realization 24 hours after installation.
- Overlap the 2 sheets till the potential pattern match is achieved.
- The overlapping will be double cut in one step or 2 in case of thick flooring alongside a metal ruler.

! **Result should be an extremely tight joint.**

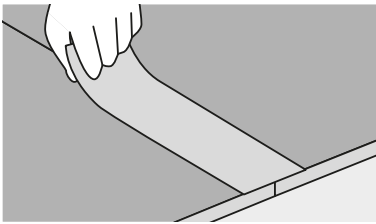

- Fix a special masking tape, centred over the cut seam, then cut the masking tape with the rolling knife within the seam.
- Apply the cold welding liquid by pressing the needle deeply into the seam.

! **Important: ensure you apply enough liquid along the entire joint.**

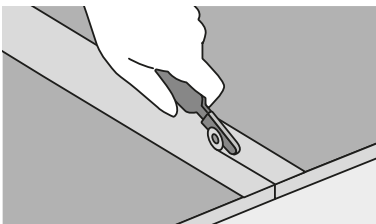

► Apply cold welding solution

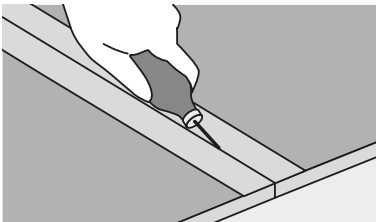

- After 10 minutes the cold-welding liquid on the masking tape should be dry and the tape is removed carefully backwards.

! **The seam can be walked on after 24h.**

4.1 SPECIFIC PRODUCTS

For the following products: Linoleum, conductive floorcovering, stairs, wet room concept, please refer to specific installation instructions.

4.2 ACCESSORIES

Many accessories are available to complete the installation: stairs profiles and borders, warning strips and signage, wall profiles, skirting...

5. REMINDER - Tarkett LOOK/TOUCH

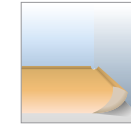
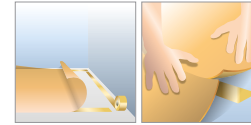
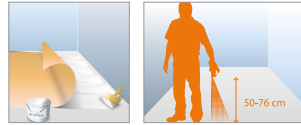

Type of subfloor - Installation	Fully Glued - Large Area > 25 m ²	Semi-Glued - Medium areas < 25 m ²	Loose Lay - Small areas < 12 m ²
NEW SUBFLOOR	✓	✓	✓
	The subfloor must be level, flat, clean, free from marks (no felt pen, marker of any type, ballpoint pens, paint, etc., that could cause discoloration due to migration), dry, solid, smooth and not exposed to moisture. Absorbency must be checked and corrected if needed with an appropriate primer or levelling compound.		
Linoleum coverings	✓	✓	✓
	Existing flooring must be in good condition (no disbonding, no cracks...) and cleaned (grease and dust removed). Vinyl Rolls is not recommended for installation on very flexible plastic coverings (textile or foam backing).		
Old Vinyl floor covering	✗		
	These would be very flexible plastic coverings (textile or foam in the backing). Please remove any existing vinyl covering before installation.		
Carpet and other textile coverings	✗		
	Remove the flooring before the installation		
Parquet and laminate flooring (glued down and floating)	✓	✓	✓
	Where there are no joints and the strips are not loose; any loose plank must be secured.		
	Make sure to sand and vacuum existing wooden flooring before installation. If there is a risk to block humidity in the subfloor, glued installation is not recommended.	-	-
Ceramic tiled flooring	✓	✓	✓
	Installation on tiles could cause telegraphing effect (visible joints of tiling on the Vinyl Rolls surface). That's why Vinyl Rolls is not recommended on tiling. A leveling compound has to be used first to ensure level and flatness. When joints are not visible, loose laying or gluing can be admitted. Grease and dust have to be removed.		
Accessories to be used for installation	Tarko Spray References: GB/FR/DE/NL/PL: 1460 003 GB/SW/SPA/IT/PT: 1460 008	For Semi Glued and loose laid installation, double sided tape adhesive is recommended. The aim is to ease the installation, to maintain the floor in place and when installed to secure it.	
Compatibility underfloor heating	✓	✓	✓

5. REMINDER - Tarkett RELAX



Type of subfloor - Installation	Fully Glued	Semi-Glued	Loose Lay
NEW SUBFLOOR	✓	✓	✓
	The subfloor must be level, flat, clean, free from marks (no felt pen, marker of any type, ballpoint pens, paint, etc., that could cause discoloration due to migration), dry, solid, smooth and not exposed to moisture. Absorbency must be checked and corrected if needed with an appropriate primer or levelling compound.		
Linoleum coverings	✓	✓	✓
	Existing flooring must be in good condition (no disbonding, no cracks...) and cleaned (grease and dust removed). Vinyl Rolls is not recommended for installation on very flexible plastic coverings (textile or foam backing).		
Old Vinyl floor covering	✗		
	These would be very flexible plastic coverings (textile or foam in the backing). Please remove any existing vinyl covering before installation.		
Carpet and other textile coverings	✗		
	Remove the flooring before the installation		
Parquet and laminate flooring (glued down and floating)	✓	✓	✓
	Where there are no joints and the strips are not loose; any loose plank must be secured.		
	Make sure to sand and vacuum existing wooden flooring before installation. If there is a risk to block humidity in the subfloor, glued installation is not recommended.		-
Ceramic tiled flooring	✓	✓	✓
	Installation on tiles could cause telegraphing effect (visible joints of tiling on the Vinyl Rolls surface). That's why Vinyl Rolls is not recommended on tiling. A leveling compound has to be used first to ensure level and flatness. When joints are not visible, loose laying or gluing can be admitted. Grease and dust have to be removed.		
Accessories to be used for installation	Tarko Spray References: GB/FR/DE/NL/PL: 1460 003 GB/SW/SPA/IT/PT: 1460 008	For Semi Glued and loose laid installation, double sided tape adhesive is recommended. The aim is to ease the installation, to maintain the floor in place and when installed to secure it.	
Compatibility underfloor heating	✓	✓	✓